

MEDICATION WASTAGE AND ITS IMPACT ON ENVIRONMENT: EVIDENCE FROM MALAYSIA

Azad, A. K.^{1*}; Muhammad, K.R.²; Hossin, M.M.³; Robiul, I.⁴; Abdullahi, M.M.⁵; Islam, M.A.⁶

¹Faculty of Pharmacy, International Islamic University Malaysia (IIUM), Kuantan, Pahang, Malaysia

²Faculty of Economics and Management Sciences, International Islamic University Malaysia, Kuala Lumpur, Malaysia

³Faculty of Business and Accountancy, University of Malaya, Kuala Lumpur, Malaysia

⁴Institute of Islamic Banking and Finance, International Islamic University Malaysia, Kuala Lumpur, Malaysia

⁵Faculty of Pharmacy, International Islamic University Malaysia (IIUM), Kuantan, Pahang, Malaysia

⁶Faculty of Sciences, International Islamic University Malaysia (IIUM), Kuantan, Pahang, Malaysia

*azad2011iium@gmail.com

Abstract

The purpose of this study is to investigate the critical factors that have impact on environment causes of unused medication. The current study is a descriptive cross-sectional audit involving with patients based on a structured questionnaire format with answer sets. The data is analyzed using partial least square method. The results revealed that excess supplied, expired medicine, changed treatment and side effects have a significant impact on unused medication. In addition, overall unused medication has a significant relationship with environmental effect. In contrast, although excess supplied and side effects have not significant impact on environmental effect, but expired medicine and changed treatment have a significant impact on environmental effect. This survey results suggested; there are few factors which increased the volume of leftover medicine and it has led to an enhanced international awareness of the potential detrimental effects on the environment. More exertion is necessary to raise awareness of people in general as an initial step in promoting behavioral change in connection to medication wastage.

Keywords: Medication Waste, Leftover Medicine, Environment, Disposal, Expired medicine

Introduction

Medicinal waste is a subset of strong waste and is characterized as any strong waste which is produced in the conclusion, treatment (e.g. Procurement of medicinal administrations), or inoculation of human creatures or creatures in exploration relating there to, or in the generation and testing of biological [1]. The worldwide increment in the utilization of pharmaceuticals had leads to an improved international awareness of the potential inconvenient consequences for the earth from the transfer of these mixes either to landfills or to the sea-going environment [2]. For instance, even follow levels of ethinyl estradiol (the dynamic segment of a typical oral preventative) found in conduits has been appeared to debilitate sexual advancement and the feminization of fish [3]. The vicinity of anti-toxins in conduits has sway on the microscopic organisms present and may prompt anti-toxin resistance [4].

Dispose of pharmaceuticals conceivably represent a noteworthy environmental risk and capacity of unused medicine in the household providers an expanded risk of incidental adolescence poisonings [5]. Wellbeing strategies that offer rise to expanded drug waste and also improper disposal of household pharmaceuticals possibly increment these issues [6]. One assessment demonstrates that about 5.2 million individuals including 4 million kids die every year from waste-related sicknesses. All around, the measure of metropolitan waste created will twofold by the year 2000 and fourfold by year 2025 as reported. Connected with this circumstance agenda 21, received in the United Nations Conference on Environment and Development (UNCED) set the following objectives and focuses as to waste management services in urban communities:

In addition, anti-ineffective medications and anti-neoplastic are typified to postpone discharge to the environment and keep away from concentrations [7]. A very little amount of solid and semi-solid pharmaceuticals, normally not more than 1% of the total day by day waste, can be discarded specifically in a landfill with large volumes of metropolitan solid waste, if no other reasonable technique is accessible. Past exploration has demonstrated that the adjustment of dispensing may have prompts a lot of medications with a vast financial quality being come back to drug stores [8]. Worldwide studies have proposed that the volume and the expense of medications that are come back to drug stores represents only a little divide of undesirable medications that are discard yearly or stay in the community unused. Thinks about in the United

Kingdom, found that only 22% of unused medications are come back to a drug store [9]. like the 23% reported in a USA study [10]. This is a change on the figure of just 2% came back to us drug stores 10 years prior [11]. Focused on campaigns can impact the way that patients handle undesirable medicines [12]. To discover the potential natural effect of improperly disposed medications in Malaysia, it is important to decide the measure of unused medicines that are not at present came back to a drug store and discarded by means of the landfill or water frameworks. Furthermore, if the purposes behind why there are undesirable or unused pharmaceuticals in patients' family can be distinguished, it may be conceivable to target systems to minimize wastage and energize sheltered and proper transfer of these medications. Figure 1 present a conceptual model of unused medication that has an impact on environmental effect. In this study we report the results of questionnaire administered among the students of Kuantan and Gombak campus of International Islamic University Malaysia.

Methods

This was a descriptive cross-sectional survey involving with patients based on a structured questionnaire format. This study carried out in the health center (Gombak campus, Selangor) and (Kuantan campus, Pahang) of the International Islamic University Malaysia.

The study populations include educated adults that are able to read clearly of all questions. All the respondents who fulfilled the inclusion criteria were selected [1]. This study period was from February 2014 to November 2015. The population for the study consists of undergraduate, masters and doctoral students who took medication from the health center of International Islamic university Malaysia (IIUM). The respondents were chosen because they take treatment, which makes them knowledgeable and experience about medication and unused medication. Questionnaires were distributed randomly among students from different faculty at IIUM Gombak and Kuantan campus. A total of 231 usable responses were received out of the 500 distributed questionnaires, which yielded a usable response rate of 46.2 %. G*Power version 3.1.9.2 was utilized to measure the power of 231 usable samples. Utilizing G*Power with an effect size of 0.15 and factual importance (a level) of 0.01 yielded a power of 0.990, which is above 0.80 and implies a satisfactory level of sample power in the present study [13]. These outcomes demonstrate that the proposed sample size of the present study shows the requisite power to reject the null hypotheses of the study as suggested by Faul [14]. In terms of inclusion criteria, respondents, currently using or had previously took medicine according to prescription within the past three months. However, in terms of exclusion criteria, Respondents had previously taken medicine without prescription within past three months. The questionnaire was placed by the interviewer to the individual respondents and collected question-sheet with their answers.

The questionnaire was divided into two sections. The first section asked for demographic data including age, gender, ethnic group and educational level. In the second section, questions about the most influential factors which responsible to increase the volume of medication unused.

A series of questions with predefined answer sets were used to ask about collection of medications, why there may be unused medications, which factor increase the volume of leftover medication etc. The order in which the predefined answer sets were displayed was changed for each question to ensure that the respondent read all answers and to minimize selection bias of the displayed answer. This study is led taking into account confirmatory factor analysis (CFA) which tests whether the constructs impacts the reactions in an anticipated manner. Basic mathematical statement displaying is utilized with partial least square (PLS) system. This study utilized PLS-SEM calculation for evaluating the way coefficients and parameters in a way that minimizes the measure of unexplained variance and amplifies the explained variance.

Moreover, the concentrate likewise connected bootstrapping technique to test the coefficients for the noteworthiness of the path modeling. The yield of bootstrapping results additionally displays the paths corresponding to every theory. Essentially, assumed significance level of the t-value for every path of 1.645 shows a critical contrast at 0.05 and 2.326 expect a significance distinction at 0.01. The convergent validity is clarified by factor loading more noteworthy than 0.70, and the average variance extracted (AVE) ought to be more prominent than 0.50 [15]. Discriminant validity alludes to the level of specific construct which delineated by the square foundation of the AVE being greater than any of the between develops relationships. The composite reliability is generally deciphered similarly as Cronbach's alpha and changes between 0 and 1 [14], in which higher values demonstrates larger amounts of significant and reliability (Figure 1).

Results

A total of 231 students from different faculty in IIUM at Gombak and Kuantan campus comprised the final sample. Most of the respondents are male at 67.7 % and 32.3 % are female. With respect to marital status, 47.2 are single and 52.8 % are married. In terms of nationality, 31.2% are Malaysian and 68.8% are non-Malaysia. Regarding the academic capabilities of the respondents, the sequence in descending order is Bachelor's Degree

(68.0 %), Master's Degree (21.0 %), Certificate/Diploma (7.7 %), and PhD/Doctorate (3.3 %). Common method bias can be risky at the point when a single latent variable records for most of the explained variance. Consequences of the un-rotated factor analysis show that the initially normalized linear combination explains just 43.28 % of the aggregate 71.68 % variance, subsequently affirming that common method bias was not a difficult issue in the study. The reliability and validity of the reflective constructs were surveyed. Composite reliability (CR) was surveyed regarding inner reliability, which is comparative to Cronbach's alpha. Table 1 demonstrates that the CR of all variables was above 0.7, which fulfilled the general guideline proposed Hair et al., (2013) and he recommended the acknowledgment of items with loadings of no less than 0.6. Individual items reliability was sensibly judged, in light of the fact that the loadings connected with each scale were all greater than 0.6. Convergent validity was assessed utilizing average variance extracted (AVE). The AVEs of all of the factors were above 0.5, signifying an attractive level of convergent validity. Overall, these findings indicate the measurement model has achieved good convergent validity. The Cronbach's alpha of all the constructs was greater than 0.70, which indicate the good reliability of all measures. However, the highest Cronbach's alpha of this study was unused medication (0.826), which supports a good internal consistency of the items and the lowest Cronbach's alpha was side effects (0.761), which supports low inter-item correlations.

Two methodologies were utilized to survey the discriminant validity of the factors. To begin with, the cross loadings of pointers were analyzed, in which no indicator were higher than any contradicting construct [15]. Second, the square root of AVE for every construct should exceed the inter-correlations of the construct with other model constructs (Table 2). Both examinations affirmed the discriminant validity of all constructs. As appeared in Table 2, expired medicine item (mean = 3.009), changed treatment (mean=3.332), excess supplied (mean=3.392), unused medication (mean=3.654), environmental effect (mean=2.370) and side effect (mean = 3.082) came to satisfactory. The unused medication is high (mean= 3.654) and environmental effect is low (mean = 2.370) from the participants' perspective are imperative discoveries in the study.

The measurement model yielded acceptable results, and the structural model was assessed along these lines. The predictive accuracy of the model was assessed based on the explained variance portion. Results propose that the model is able to do explaining 69.2 and 79.9 % of the variance in unused medication and environmental effect respectively. The blindfolding approach, proposed by [16] was taken after to compute the cross-validated (CV) communality and redundancy. The mean of the CV communality indices can be utilized to measure the nature of the measurement model in the event that they are sure for all blocks of variables. The nature of each basic mathematical statement is measured rather by the CV-

redundancy list (Stone–Geisser Q2). The mean of the CV-redundancy lists (Q2) identified with the endogenous blocks can be utilized to quantify the nature of the structural model, if they are certain for every single endogenous blocks (Chin, 2001). The present study got 0.353 for average CV-redundancy, and 0.551 for average CV-communality, values that exceed the prescribe standard of 0.30 [17]. Nonparametric bootstrapping was applied on 5000 replications to test the structural model [18]. The significance of the direct impacts determined by the examination model is assessed (Table 3). All ways paths coefficient are significant except H1b and H1h. Results show that excess supplied variable ($b=0.331$, $p<0.01$), expired medicine ($b=0.184$, $p<0.05$), changed treatment ($b=0.163$, $p<0.01$) and side effects ($b=0.228$, $p<0.01$) positively affect unused medication. The effect of unused medication on environmental effect is significant and positive ($b=0.241$, $p<0.01$). As such H1a, H1b, H1c, H1d and H2 are supported (Figure 2). On the other hand, Hayes, (2009) suggests the bootstrapping procedure as an approach to test indirect effects [19]. The t value for the indirect effect is obtained by dividing the indirect effect (ab) by the standard error (SE) of the indirect effect. The SE is the standard deviation of the repeated bootstrap estimates of the indirect effect. Table 3 shows that the indirect effects of expired medicine ($b=0.273$, $p<0.01$) and changed treatment ($b=0.269$, $p<0.01$) positively affect to environmental effect, whilst, excess supplied ($b=0.106$, $p>0.05$) and side effects ($b=0.091$, $p>0.05$) have not significant impact on environmental effect. Thus, H3b and H3c are supported and H3a and H3d are not supported.

Discussion

The objective of this study is to look opinion of students of the International Islamic University Malaysia and relationship between factors and effects on environment of leftover medications. Medicine assumes an essential part in treating numerous conditions and ailments and when they are no more required it is vital to discard them appropriately to lessen hurt from inadvertent presentation or deliberate abuse [20]. Unused medications are giving direct effects on environment; therefore it is high time to concentrate about the unwanted medications and to find out the exact reasons of unused medicines. Previous study reported the most influential factors (expired medicine, changed treatment, excess supplied of medicine, side effects) that can increase

the volume of unused medication which effect on environment directly. However, people are not much aware about the medication waste and its significant negative impact on environment as well as human health and ecosystem. Pharmaceuticals and its metabolites constituents are going to landfill and sea via garbage or trash and sewerage canal [21].

Pharmaceuticals designed for humans and animals often remain unused for a variety of reasons, ranging from expiration to a patient's non-compliance [22]. These leftover, accumulated drugs represent sub-optimal delivery of health care and the potential for environmentally unsound disposal, which can pose exposure risks for humans and wildlife [23]. A major unknown with respect to drugs as pollutants is what fractions of drug residues occurring in the ambient environment result from discarding leftover drugs [24]. In addition, leftover medicines are going to river and sea via trash and drainage system and mixed with soil; it has really potential to cause harm to aquatic life viz feminization and bacterial resistance [9]. In this study, the structured questionnaire was distributed among the student of the International Islamic University Malaysia and it was collected with their valuable opinion. The analyzed data were revealed that most of the student supported with questionnaire (** $p < 0.01$) and it was indicated the mentioned factors are responsible to make medication be unused and directly or indirectly it is giving negative impact on environment. The hypotheses testing of excess supplied (ES), expired medicine (EM), change treatment (CT), side effect (SF) with their significant t-value (3.76**, 2.21*, 2.36** and 3.04**) were directly responsible to increase the volume of unused medicine and it is effect on environment significantly. Most of the respondents were agreed with this statement that unused medicine have negative effects on environment significantly (** $p < 0.01$). In indirect effect of several parameters on environment, there are two positive response with significant t-value (** $p < 0.01$) (2.56** and 3.16**) among four factors. Lastly, the analyzed data revealed; most of the respondents were agreed with the above mentioned questionnaire that really influences to increase the volume of leftover medicine and it is giving direct or indirect negative impact on environment.

The study report indicate that the necessary for appropriate system implement to collect leftover medications from home or individual. At the same time, authority of health sector should arrange seminar for all practitioner, nurse, pharmacist and pharmacy shop or retailer to encourage reducing the excess supply of medicine and making aware about the negative impact of unused medications to patient while they visit.

Acknowledgments

This study was funded by the South-East Asian Co-operation Foundation (SEACO Foundation). I am gratifying to Al-Haj Md Hasmotullah, for his cordial encouragement and assistance and my lovely wife who have always inspired me.

References

1. Azad, M. A. K., Akhtaruzzaman, M. R. H. A. M., Akhter, S. M., Uddin, M., & Rahman, M. M., 2012. Disposal Practice for Unused Medications among the Students of the International Islamic University Malaysia. *Journal of Applied Pharmaceutical Science*, 2012; 2(07):101-106.
2. Law, A. V., Sakharkar, P., Zargarzadeh, A., Tai, B. W. B., Hess, K., Hata, M., & Park, T. J. Taking stock of medication wastage: unused medications in US households. *Research in Social and Administrative Pharmacy*, 2015; 11(4):571-578.
3. Jobling, S., Williams, R., Johnson, A., Taylor, A., Gross-Sorokin, M., Nolan, M. & Brighty, G. Predicted exposures to steroid estrogens in UK rivers correlate with widespread sexual disruption in wild fish populations, 2005;114(1):32-39.
4. Costanzo, S. D., Murby, J., & Bates, J. Ecosystem response to antibiotics entering the aquatic environment. *Marine Pollution Bulletin*, 2005;51(1):218-223.
5. Franklin, R. L., & Rodgers, G. B. Unintentional child poisonings treated in United States hospital emergency departments: national estimates of incident cases, population-based poisoning rates, and product involvement. *Pediatrics*, 2008; 122(6):1244-1251.
6. Beirens, T. M., Van Beeck, E. F., Dekker, R., Brug, J., & Raat, H. Unsafe storage of poisons in homes with toddlers. *Accident Analysis & Prevention*, 2006;38(4):772-776.
7. Bowman, S., Cooper, D., Hooks, D., Khan, E., MA, T. S. P., & Sledge, A. The Edge of Chaos Household Hazardous Waste Disposal II: Prescription Medication in Jefferson County Wastewater Proceedings from the Wicked Problem Discussion 1 April 2015. Proceedings from the Wicked Problem Discussion.
8. Braund, R., Chuah, F., Gilbert, R., Gn, G., Soh, A., Tan, L. & Yuen, Y. C.,. Identification of the reasons for medication returns. *New Zealand Family Physician*, 2008;35(4):248-52.
9. Bound, J. P., & Voulvoulis, N.,. Household disposal of pharmaceuticals as a pathway for aquatic contamination in the United Kingdom. *Environmental Health Perspectives*, 2005;113 (12):1705-1711.
10. Seehusen, D. A., & Edwards, J.,. Patient practices and beliefs concerning disposal of medications. *The Journal of the American Board of Family Medicine*, 2006;19(6):542-547.
11. Kuspis, D. A., & Krenzelok, E. P. What happens to expired medications? A survey of community medication disposal. *Veterinary and Human Toxicology*, 1996;38(1):48-49.
12. Persson, M., Sabelström, E., & Gunnarsson, B., 2009. Handling of unused prescription drugs—knowledge, behavior and attitude among Swedish people. *Environment International*, 2009;35(5):771-774.
13. Chin WW.,. PLS-Graph User's Guide Version 3.0. Soft Modeling, 2001, Houston, TX.
14. Faul, F., Erdfelder, E., Buchner, A., & Lang, A. G.,. Statistical power analyses using G* Power 3.1: Tests for correlation and regression analyses. *Behavior Research Methods*, 2009;41(4):1149-1160.
15. Hair, J. F., Ringle, C. M., & Sarstedt, M.,. Editorial-partial least squares structural equation modeling: Rigorous applications, better results and higher acceptance. *Long Range Planning*, 2013;46(1-2):1-12.
16. Wold H.,. Soft modeling: the basic design and some extensions. In: Joëreskog KG, Wold H (eds) *Systems under indirect observation. Causality, structure, prediction, Part 1*. North-Holland, Amsterdam, 1982;1-54.
17. Tenenhaus M, Esposito V, Chatelin YM, Lauro C.,. PLS path modeling. *Computational Statistics & Data Analysis*, 2005;48(1):159-205.
18. Wetzels M, Odekerken-Schroöder G, van Oppen C.,. Using PLS path modeling for assessing hierarchical construct models: guidelines and empirical illustration. *MIS Q*, 2009;33(1):177-195.
19. Hayes AF.,. Beyond Baron and Kenny: statistical mediation analysis in the new millennium. *Communication Monographs*, 2009;76(4):408-420.
20. Bergen, P. J., Hussainy, S. Y., George, J., Kong, D. C., & Kirkpatrick, C. M.,. Safe disposal of prescribed medicines. *Australian Prescriber*, 2015;38(3):90.
21. Abahussain, E., Waheedi, M., & Koshy, S.,. Practice, awareness and opinion of pharmacists toward disposal of unwanted medications in Kuwait. *Saudi Pharmaceutical Journal*, 2012;20(3):195-201.
22. Kozak, M. A., Melton, J. R., Gernant, S. A., & Snyder, M. E.,. A needs assessment of unused and expired medication disposal practices: A study from the Medication Safety Research Network of Indiana. *Research in Social and Administrative Pharmacy*, 2015;11(6).
23. Glassmeyer, S. T., Hinchey, E. K., Boehme, S. E., Daughton, C. G., Ruhoy, I. S., Conerly, O. & Sykes, K.,. Disposal practices for unwanted residential medications in the United States. *Environment International*, 2009;35(3):566-572.
24. Kümmerer, K. The presence of pharmaceuticals in the environment due to human use—present knowledge and future challenges. *Journal of Environmental Management*, 2009;90 (8), 2354-2366.

Table 1. Convergent validity

Constructs	Items	Loadings	AVE	CR
Excess Supplied (CA= 0.808)	Excess medication leads to raise the volume of unused or waste of medication.	0.816	0.636	0.874
	I think doctors are prescribing a large number of medicines that are not necessary for a particular treatment.	0.744		
	I think patients would like to request to the physician to give more medicine.	0.789		
	I think the physicians are not given full concentration to patients.	0.836		
Expired Medicine (CA= 0.763)	I think excess supplied of medicine leads to raise the volume of expired medicine.	0.705	0.686	0.849
	I think dispensary shops are selling medicines which will be expired within a short time.	0.768		
	Patients should not keep their medication at home for a long time because it causes to make medicine expired.	0.791		
	Some patients are prescribed a several types of medicines by physicians at one time.	0.793		
Changed Treatment (CA= 0.815)	Physicians should not add and drop patient's prescription.	0.844	0.644	0.878
	Most of the dispensary shop is not taken-back medicine from individual patient who changed their treatment.	0.805		
	Most of the patients do not know that changed of treatment causes medication waste.	0.746		
	The physician should prescribe with the proper diagnosis of the diseases which can reduce the volume of medication waste.	0.813		
Side Effects (CA= 0.761)	When I take medicines and feel side effect, I usually stop to take it.	0.784	0.684	0.848
	I didn't return back my rest of medicine to the pharmacy, when I discontinue taking them.	0.715		
	Side effect leads to increase unused medication.	0.717		
	Lack of information about patient and poor explanation to the physicians; it makes to wrong prescription.	0.833		
Unused Medication (CA= 0.826)	I don't have proper knowledge about unused medication.	0.811	0.658	0.885
	I am not aware about medication waste.	0.865		
	Government does not organize any campaign on medication waste to make people aware.	0.747		
	Hospitals, clinics and diagnostic center are not aware to reduce the medication waste.	0.816		
Environmental Effects (CA= 0.782)	Government does not have enough facilities to dispose unused medication.	0.795	0.606	0.859
	Unused medication leads to bacterial resistance.	0.794		
	Unused medication directly going to the water drainage system which changing river and marine ecosystem.	0.799		
	Medication waste leads to infertile land.	0.721		

Note: AVE= Average variance extracted, CR=Construct reliability, CA= Cronbach's alpha

Table 2. Discriminant validity

	Mean	SD	EM	CT	ES	UM	EE	SE
EM	3.009	0.952	0.828					
CT	3.332	0.789	0.747	0.802				
ES	3.392	0.730	0.729	0.724	0.797			
UM	3.654	0.653	0.705	0.764	0.776	0.811		
EE	2.370	0.645	0.626	0.631	0.695	0.704	0.778	
SE	3.082	0.628	0.500	0.592	0.629	0.747	0.681	0.827

Note: ES= Excess Supplied, EM= Expired Medicine, CT= Changed Treatment, SE= Side Effects, UM= Unused Medication, EE= Environmental Effects. Bold values represent the square root of average variance extracted (AVE).

Table 3. Hypotheses testing

Hypotheses	Relationship	Coefficien t	Std. Error	t-value	Supported
Direct effect					
H1a	ES -> UM	0.331	0.088	3.76**	Yes
H1b	EM -> UM	0.184	0.083	2.21*	Yes
H1c	CT -> UM	0.163	0.069	2.36**	Yes
H1d	SE -> UM	0.228	0.075	3.04**	Yes
H2	UM -> EE	0.241	0.094	2.56**	Yes
Indirect effect					
H3a	ES -> UM -> EE	0.106	0.079	1.34	No
H3b	EM -> UM -> EE	0.273	0.106	2.56**	Yes
H3c	CT -> UM -> EE	0.269	0.085	3.16**	Yes
H3d	SE -> UM -> EE	0.091	0.113	0.80	No

Note: Significant level at **p < 0.01; *p < 0.05.

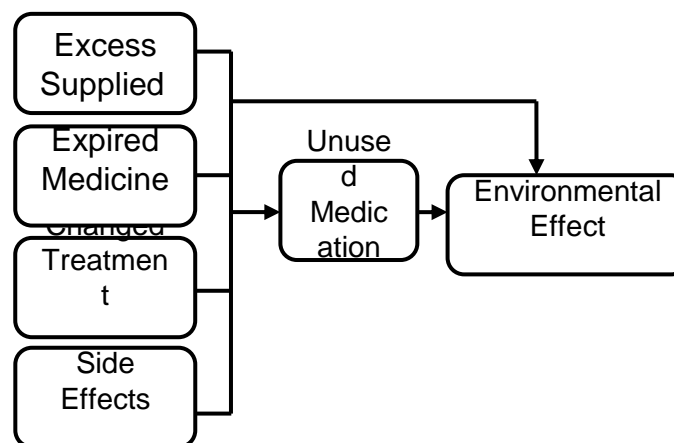
**Figure 1.** Conceptual Framework

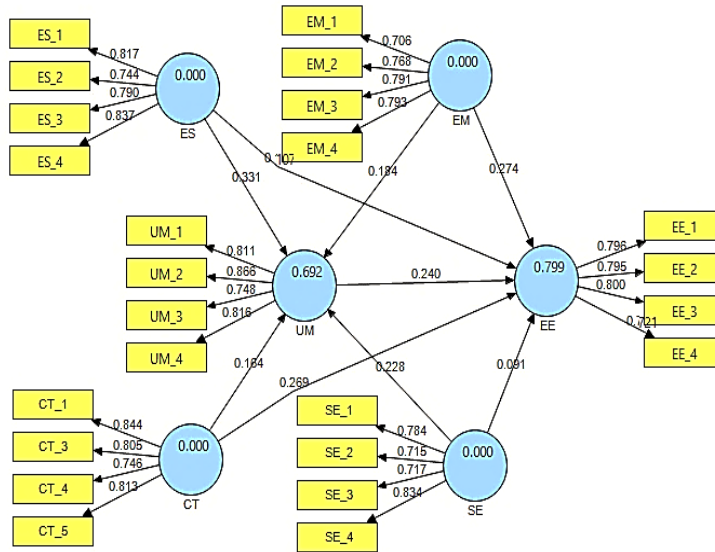

Figure 2. Structural model